

White Paper

Security Cameras, CATV, GPS and Satellite Protection

Security Cameras, CATV, GPS & Satellite Protection

Outdoor Closed Circuit Television (CCTV) Security Cameras can be a prime target for lightning. They are usually mounted on a building or other vantage point such as a metal or wood pole. A lightning strike can not only destroy the camera, but can damage your control console due to energy flowing back through the coax and camera power wiring.

When lightning strikes a tower or other large structure, there is a high peak voltage at the strike point flowing outward and downward through any path it can find to earth ground. A support pole develops a high $L di/dt$ peak voltage drop along its length to earth ground. A large steel reinforced structure can conduct the energy to earth ground through its steel reinforced concrete footers and electrical ground system. A camera mounted and grounded to a building with steel reinforced construction will usually have less inductance to ground than a camera mounted on a self-supported tower or pole. Less inductance to earth ground means less peak voltage at the camera.

When lightning strikes a wood or other insulating support, whatever voltage is necessary to continue the arc is developed at the strike point to overcome the resistance of the non-conducting structure. This usually has catastrophic results.

The same conditions exist for both examples. A high peak voltage occurs at the strike point with reference to earth ground. The video and power wiring to the camera are insulated from the strike point by the electrical circuitry involved and the external covering around the wire. The energy will flow through the camera in an attempt to equalize the wiring with the instantaneous peak voltage occurring at the strike point.

To protect your equipment, you must provide a low inductance path to earth ground for lightning energy and install properly rated protectors for all interconnected wiring from the camera to the operating console. A properly rated protector at the camera allows the wiring to be equalized to the peak voltage at the strike point without allowing damaging voltages across the camera circuitry. An appropriate protector at the console blocks damaging voltages incoming from the camera wiring.

A camera mounted on a building should be grounded to the building's structural steel as near the camera as possible. Use 1-1/2 inch copper strap. If the camera is mounted on a metal pole, it should be grounded to the pole and a proper ground system installed at the base. When mounted on a wood or other insulating support, the camera should be grounded to a 1-1/2 inch copper strap running from the camera mount to a proper ground system installed at the base. An additional 1-1/2 inch copper strap would run from a lightning rod or diverter to the ground system at the base. Separate the two straps on opposite sides of the pole and connect together below grade. Side mounting the camera or providing a diverter above the camera provides some additional protection from a direct strike.

A proper ground system would be capable of dispersing large amounts of lightning energy (usually electrons) into earth ground quickly. The faster it disperses electrons, the less time there is for damaging surges to flow in the coax and power wiring back toward your operating console.

The ground system under a metal pole could be a combination of a steel reinforced concrete base (Ufer Ground), radials and ground rods. If possible, exothermically weld a #2/0 AWG stranded wire to the steel mesh before pouring concrete. Attach this wire to a "J" bolt on top of the pad after the pole is erected. Use another wire welded to the mesh to attach additional radials with ground rods. If the concrete base already exists, attach additional radials with ground rods to any "J" bolt.

Be sure to remove paint and corrosion. Use a double nut attachment with joint compound. Space additional ground rods at least two times their length from each other and from the "Ufer Ground." (See illustration.)

When grounding a wood or insulated support, tie together both 1-1/2 inch straps, below grade, to a radial strap and ground rod system. A good layout for a "rapid response" low resistance/inductance ground system would be four 8-foot ground rods, one at the base and three spaced 120 degrees and 16 feet out forming an equilateral triangle centered on the base of the support. Each ground rod would directly connect with below grade 1-1/2 inch straps to the rod under the pole. (See illustration.)

Protector type varies depending on camera power requirements and environment. Numerous configurations are possible.

For example: A camera powered by 120 Vac would require a PolyPhaser IS-PLDO-120-15A at the camera. If there is insufficient space in the weatherproof housing, an IS-PSP-120 MOV/Gas tube hardwired shunt protector at the camera power input can be substituted.

If the camera is powered by 24 Vac, a PolyPhaser IS-SPTV twisted pair protector could be placed at Ufer Ground the camera and an IS-PSP-120 protector wired across the primary of the 120Vac to 24Vac power transformer at the console end of the cable.

In both examples an IS-75BB (75 ohm BNC female connectors) would be inserted in the video coax at the camera and control console ends. The protectors should be in a weatherproof location unless a water-tight version is ordered.

Some cameras use the coax cable for 24 Volts dc power input and video output. The power is inserted at the control console end and "picked off" the coax in the camera.

A PolyPhaser Part # 093-0421W-A [Special] (75BB +26 Volts, <100 mA, dc-15MHz) could be inserted in the coax at the camera and control console ends.

"Ground Loops" can occur whenever long video coax runs are used. The usual symptoms include horizontal black bars (hum bars) moving vertically through the picture. Ground Loops are created when a potential difference exists between grounds. This potential difference can allow induced pickup from power lines or current flow from dissimilar ground potentials, i.e. Power Plants or Substations.

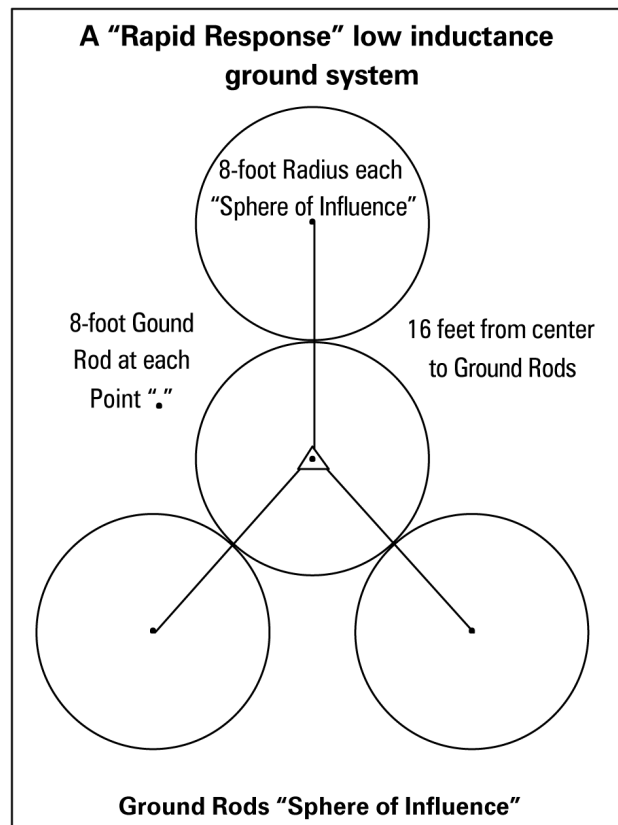
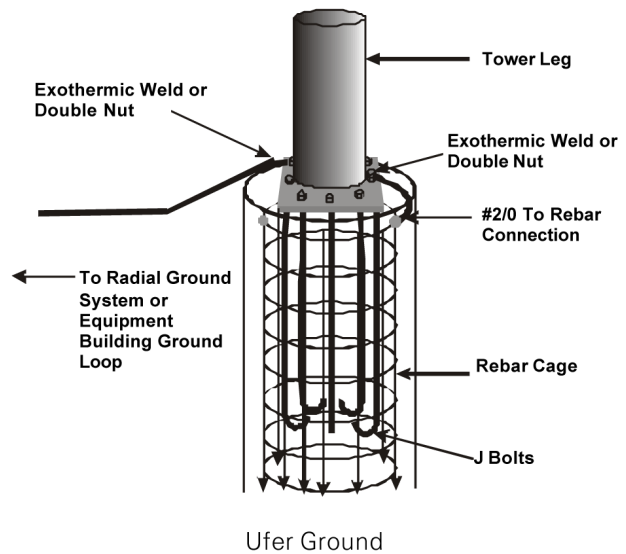

The Ground Loop can be eliminated at the camera by using an IS-75BB base band protector and insulating the camera from local ground at the top of the pole. The isolated ground adapter does not have a path to ground until a predetermined voltage from coax shield to local ground is exceeded and remains switched to ground until another lower voltage condition exists. At the control console end, an IS-75BB protects the center conductor. Note that this arrangement will only work for externally powered dc or low voltage ac powered (through a transformer) cameras with no "safety" ground.

In all cases, the IS-75BB mounted on a "single point" ground plate should be used at the console end with a few turns of coax to add series inductance before connecting to switcher or monitor. An ISPLDO-120US15A in-line ac power protector is also mounted on the ground plate with the control console and any power supplies for remote cameras plugged in to it. (See illustration.) The ground plate should be connected with 1-1/2 inch strap to an external low inductance ground system. Do not rely on the third wire ground in the ac wall socket.

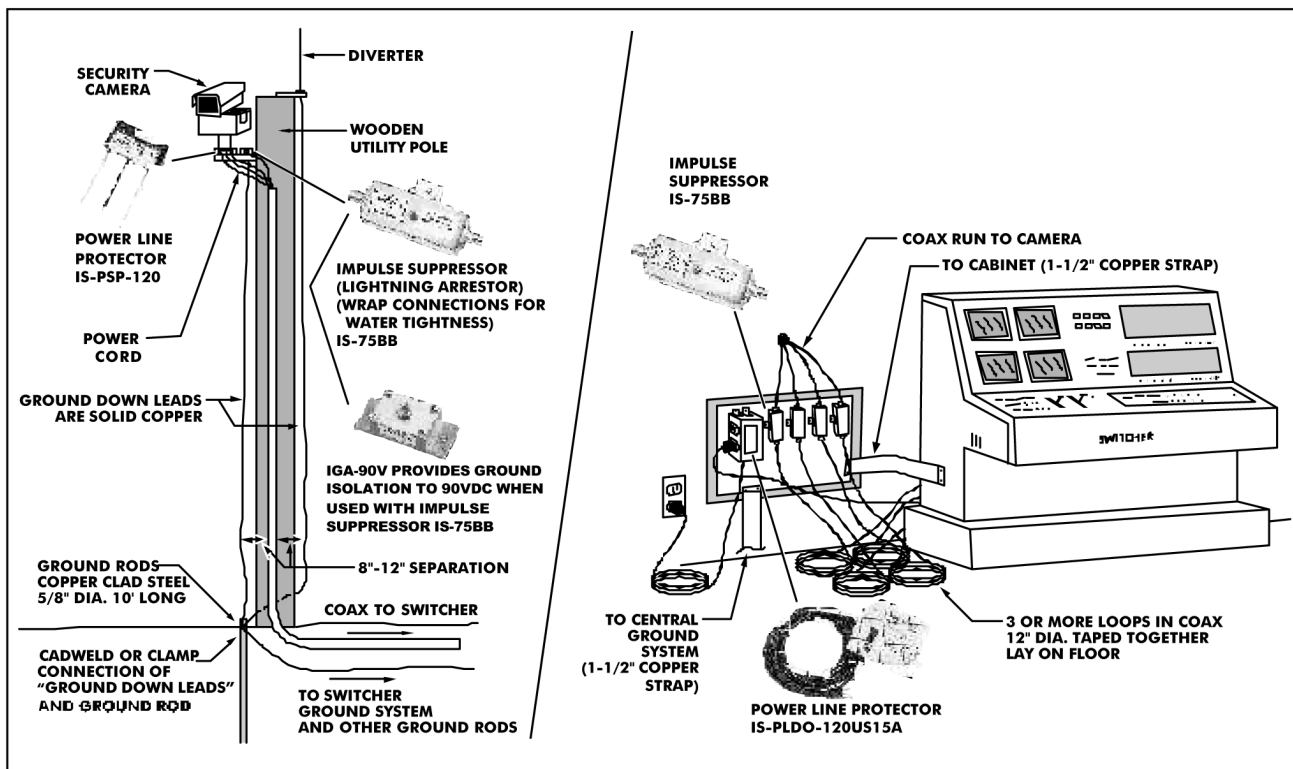

Catv Considerations

Almost everything discussed so far can be applied to a CATV head end. Trunk line amplifiers are very similar to the tower top amplifiers already described. They are powered via the coax line, usually with 60Vac (60Hz). The ac power is separated from the RF, optimally protected, then recombined on the equipment side. The power line (neutral ground at the utility entrance) should be interconnected with the cable drop ground. The interconnection should be a wire placed in the ground (buried) for low inductance (if the soil is conductive) or should be a buried strap. Getting the ground connection in place and keeping it there can be simplified if the cable entrance point is located close to the power ground location.

Gps Lightning Protection And Antenna Placement

The first consideration for a GPS antenna is a clear view of the sky, preferably 360 degrees. In the usual installation the GPS antenna is located low, close to the equipment building roof, or if an outdoor cabinet, mounted on the cabinet or very low on the adjacent monopole/tower. A direct lightning hit to the above mounted antenna is unlikely. Mounting on an equipment building roof or cabinet is the safest place since the potential rise on the outside of either of these structures would be more or less equal with the potential on the inside. The PolyPhaser protector is there to equalize the differential in potential that occurs between center conductor and shield of the coax cable on its way from the antenna to the receiver.

The zone of protection from various lightning rod types is an argued topic. Many claims are made for different configurations. If a Franklin rod is below 60 feet, we can assume a 45 degree “cone of protection”. If above, we should apply the “rolling ball” theory (see pages 2-3). If the GPS antenna is mounted on the monopole/ tower, (since this is the structure we expect to be hit) there will be an inductive voltage drop occurring during the event that will be distributed down the structure to earth ground. This voltage drop is the result of the fast rise time lightning current pulse traversing the inductance of the structure. ($E = L di/dt$). If the GPS antenna is mounted on this structure it will be elevated to a potential higher than the equipment building or cabinet. There will be current flow on the shield and center conductor of the coax cable towards the receiver. A coax cable grounding kit or PolyPhaser integrated ground entry panel will direct the shield currents toward earth. A PolyPhaser coaxial protector will “turn on” and direct any current on the center conductor towards earth. Proper shield grounding and center conductor protection are essential to receiver survival.

Questions regarding GPS LNA protection in the antenna are valid but usually not considered in this application. The antenna element at GPS frequency is usually “grounded” and does not have the capture area to couple much energy to the preamp input, the problem is with the output. In roof or cabinet mounting there is not the potential that could occur with a monopole/tower mount. If the GPS antenna support structure is elevated in potential (due to its inductance), the GPS antenna/ LNA will also be elevated to a potential determined by the voltage distribution across the structure, and the height of the GPS antenna mounting on the structure. Since the coax shield is usually common with the GPS antenna mounting bracket, current will flow down the shield. The voltage differential at the top of the coax between the shield and the not-yet-elevated center conductor will appear across the LNA output circuitry. The LNA output could be destroyed in the attempt to bring the center conductor up to shield potential. If another protector were installed at the output of the LNA, any voltage differential between center conductor and shield would “turn on” the protector. Current flow that would have gone through the LNA output now goes through the protector. The LNA would survive. The top protector could be combined with a voltage “pick-off” for power to the LNA. There are protectors in this configuration. There have not been many failures (that we know about) with LNA's. The higher the GPS antenna is mounted on the support structure, the more probability of damage.

Satellite Dish Considerations

Most satellite dish antenna pier supports are encapsulated in concrete, which retains moisture for 15 to 30 days after a rain or snow melt. It absorbs moisture quickly and yet gives up moisture very slowly. Concrete's moisture retention, its mineral content (lime and others), and its inherent pH base of more than +7 means it has a ready supply of ions to conduct current. Concrete's large volume and great area of contact with the surrounding soil allows good charge transfer to the ground.

If a 4-inch pipe is placed four to five feet down in an 18-inch diameter (augered) hole and the hole is filled with concrete, it will provide a good start for a satellite dish ground system. This type “ground” is referred to as a “Ufer,” so named after Herbert G. Ufer. (For more information on Ufer grounds, see Chapter 3.)

In areas of good soil conductivity (100 ohm-meters or better), the “Ufer” may be adequate for the antenna ground. Interconnect a below grade bare copper wire from the antenna pipe to the electrical (power) ground stake or rod. The copper wire should be 10 gauge or larger, at least 8” or deeper in the ground, and should be exothermically welded to the pipe. The weld will ensure a good mechanical and electrical connection. Exothermic welding is a simple process which joins even dissimilar metals without a problem and requires a fixture (mold), or “one shot” connection kit.

If the water table at the installation site is over 10 feet deep, the Ufer ground should be augmented with mechanically coupled pairs of 10-foot rods placed 20 feet deep and spaced 20 feet apart. The first ground rod location can be at the antenna, and the second should be 20 feet away, in the direction of the equipment building and connected to the below grade bare copper wire going to the building perimeter ground loop. Additional radials should be used to augment the Ufer grounding. RF and control cables for the system should follow the line of grounding rods which are spaced 20 feet apart (overhead view).

If the installation is in a rocky area and it is virtually impossible to install ground rods, a radial system may be used. Grounding may be accomplished by laying 10 or more lengths of 10 gauge or larger bare copper wire, at least 50 feet long in a radial fashion connected to and going out from the antenna base, much like the spokes of a wheel.

These may be laid on the surface although it is preferable to bury the wire. The antenna base must be interconnected to the equipment building perimeter ground loop.

In sandy terrain (dry sand), increase the interconnect wire size to #2 AWG or larger copper wire (copper strap may be used), and shorten the distance between the rods to 10 feet.

It is always best to measure the soil conductivity, but it is not essential to strive for a 5 ohm ground system. By using the proper I/O (Input/Output) protectors, the equipment can survive most strikes. A satellite dish system may have the following I/Os: 1) 120Vac power; 2) RF coax cable; 3) dc polarization control; 4) actuator/positioner cable. The power line can be a two-way street. If a lightning strike occurs away from the system but near a utility pole, it can travel to the equipment. A direct strike to the satellite antenna will cause currents incoming to the equipment, elevating it and exiting to the utility line, causing damage in the process.

A power line protector that plugs into the wall has the equipment power cord series inductance from the equipment to it and also has an even longer safety wire ground run to the distribution panel before it gets to the utility ground rod. The fast rise time pulse of a lightning strike, it is not really grounded at all!

A power mains protector mounted directly to the breaker box across the 240 volt mains to neutral and ground can protect the whole site from incoming surges. A second protector mounted or grounded directly to the equipment chassis will “switch” surge current incoming from the antenna to the antenna system ground and to the perimeter ground loop.

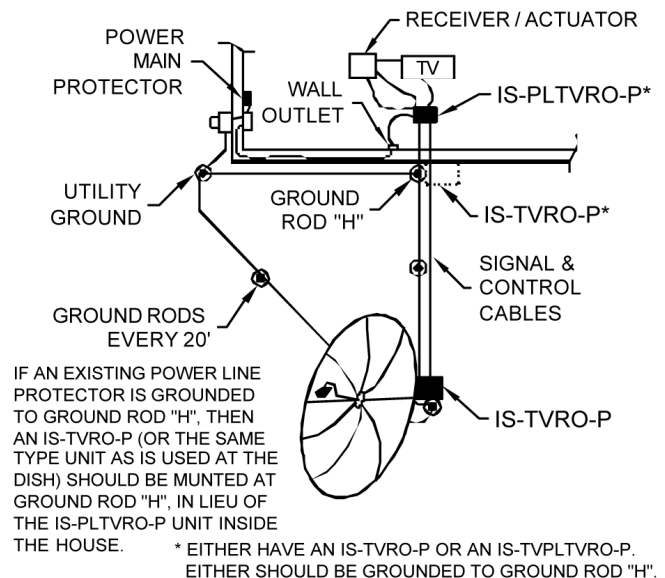

Additional radials should be used to augment the Ufer grounding. RF and control cables for the system should follow the line of grounding rods which are spaced 20 feet apart (**overhead view**).

RF Cable Protection

Surge current will propagate on the coax creating a differential in as little as 15 feet. The center conductor energy differential can damage equipment, inside (receiver) and outside (LNA, LNB, down converter, etc.). A coax protector clamping at the +22 volt level for LNB's with low loss and good VSWR over the 450 to 1450 Mhz range is required. The specifications of the protector will vary based on the type of system being installed.

Polarization Control & Actuator

The polarization rotor or polarity switch is another source of surge current to the equipment. In addition, the actuator or driver must have a protector for the controller and also the motor and switches.

The system will need two sets of protectors, one at the antenna, which is grounded to the antenna ground system, and the other at the equipment building, grounded to the perimeter ground loop.

At this point, protection has been established for the system I/Os, but in the event of a direct strike to the feed, damage can still occur to the LNA/ LNB. To help stop direct strikes, take a 10-foot rod and pound it in no more than 6 feet away from the antenna. Couple a second 10-foot rod to extend at least 2 feet above the highest point on the dish. Interconnect the rod assembly to the antenna ground system. This assembly should act as a diverter, sending up a streamer towards a stepped leader, and attracting the strike to itself.

Please contact us for questions or further information on this topic.

Contact:

Tel: (+1) 208-772-8515

Email: Sales@ProtectionGroup.com

www.protectiongroup.com